

# PERFECT PROMISES

God and his promises  
are trustworthy.

Genesis 12:1-7; 15:5-7

Numbers 30:2

## SESSION SUPPLIES

- ★ Bibles
- ★ twigs, craft sticks, balloons, fabric
- ★ old crayons
- ★ scissors and paper
- ★ paper cups
- ★ self-hardening clay
- ★ waxed paper
- ★ colored jewel beads (see activities)
- ★ photocopies of Promise Bingo (page 125)
- ★ photocopies of the Power Page! (page 45)

## MIGHTY MEMORY VERSE

Trust in the Lord with all your heart and lean not on your own understanding. Proverbs 3:5

## SESSION OBJECTIVES

During this session, children will

- ★ understand the value of promises
- ★ realize that God keeps his word
- ★ explore some of God's promises
- ★ praise God for his faithfulness

## BIBLE BACKGROUND

If the old axiom that we're known by our actions is true, then what better way to really know, trust, and have faith in God than by looking at his actions? It's by actively seeing God keep his promises that we develop a stronger assurance of his divine grace, loving protection, and marvelous forgiveness. When God promised Abraham many heirs, a new land, and countless blessings, Abraham was at least seventy-five years old and used to leading a nomadic lifestyle. But since God was the promise-maker and Abraham knew God by his actions, "Abram believed the Lord, and he [God] credited it to him as righteousness" (Genesis 15:6). God blessed Abraham because he placed his faith in the word and character of God.

Kids understand all too well the heartbreak of broken promises and the power of promises kept. But they also need to recognize that, even though promises are some-

times hard, if not impossible, for humans to keep, God never breaks his Word! Use this lesson to explore God's Word and actions and to discover how, through these perfect promises, we find faith in God himself!

## POWER FOCUS

Before class, gather one set of the following for every child: a twig, a craft stick, a piece of paper, a 4-inch square of thin fabric, an old crayon, and an inflated balloon. You may wish to put a small snip on one edge of the fabric squares to make tearing them a bit easier. If your class is very large, provide only a twig, paper, and balloon for each child. You'll also need to write the words "God's promises" on a sheet of paper.

Have kids spread out around the room and hand each child a set of items.

Say: **We're going to have some fun with these items to see which will break, tear, snap, smooch, squish, or pop. Look at the items you have and silently identify which items you know will break, tear, or pop. Don't say anything aloud yet.**

Allow a moment for kids to make their mental predictions, then say: **Now see if you can snap the twig. Can you snap it several times so the pieces are in pieces?** Pause for kids to snap their twigs, then continue with the other items in the same way, saving the balloons until last.

Invite kids to pop the balloons by sitting on them. Then ask:

- ★ **Which items were you sure were going to pop, break, or tear? How did you know?**
- ★ **Do you think all things can be broken or destroyed in some way? Explain.**
- ★ **Is there anything that can't be broken?**

Hold up the paper with the words "God's promises" written on it. **Can God's promises be broken?** Allow kids to tell their ideas and encourage them to explain why they feel as they do. Then say: **Sticks can snap, cloth can tear, paper can shred, and balloons can pop. Everything in our world can be ruined or broken in some way—but not God's promises! God keeps his promises whole and unbroken so we can trust in them. You knew your items could be broken from experience. And in the same way, we know that God keeps his promises from our own experiences and from experiences we read of in the Bible.**



Today we'll be learning about placing our faith in God's promises. We'll discover what some of God's promises are and learn about some promises God has already kept. We will also learn a new **Mighty Memory Verse** that tells us more about trusting God and finding faith in him. Let's trust each other to do a good job cleaning up our area, then we'll explore how God kept a very special promise to a very old man. Clean up the room and place the broken items in the trash. Save the broken crayons in a can for future craft projects.

## THE MIGHTY MESSAGE

Before class, collect colored beads, one of each color for each child. You'll need green, purple, and white. (For later activities, you'll also need red and blue beads.) If you can find star-shaped beads, use them for the white beads. If you can locate heart-shaped beads, use them for the red beads in the Super Scripture activity.

### POWER POINTERS

Sometimes kids give their word with "crossed fingers" because they really don't want to keep a promise. But God never crosses his fingers—he sticks to his word and keeps every promise he makes!

Gather kids and invite them to tell about special promises made to them. Then ask:

- ★ **Why are promises important to keep?**
- ★ **How does it feel when promises are broken? when they're kept?**
- ★ **What does keeping a promise say about the person who made the promise?**
- ★ **In what ways are keeping promises and trust related?**
- ★ **How can we learn about God through his promises?**

Hand each child a paper cup, then say: **God made three special promises to a man named Abraham. As we learn about the promises God made and then kept to Abraham, we'll be collecting precious jewels to remind us how God's promises are like precious treasures. As I read this passage from Genesis, see if you can identify the three special promises God made to Abraham. Put a finger in the air each time you think you know one of the promises. Ready?**

Read aloud Genesis 12:1-7 and 15:5-7. Then ask kids to identify what they think the three promises were. Say: **God promised to give Abraham a new land to live in, called Canaan. Did God give him this land?** Read Genesis 12:7 again,

then say: **God kept his first promise! Here's a green jewel to remind us of God's promise to Abraham of land.** Hand each child a green bead.

**What was God's next promise?** Read Genesis 15:5, 6 again, then say: **God promised Abraham offspring. That is, God promised that Abraham would have a child and many, many descendants to make a great nation—as many offspring as there are stars in the sky! Wow, that's a wonderful promise! And in Genesis 21, we read that Abraham and his wife Sarah did have a son, whom they named Isaac. And through Isaac and his children, a great nation was born for God!** Hand each child a white or star-shaped bead. **Here's a bead to remind you of God's starry promise to Abraham of many offspring.**

**God's third promise was that Abraham and all his descendants would be greatly blessed. When God sent Jesus to love and forgive us, we were all greatly blessed. So God kept that promise, too!** Hand each child a purple bead as you say: **Purple is the color of royalty, and it reminds us how blessed we are through Jesus the King!** Ask:

- ★ **Why does God keep his promises to us?**
- ★ **In what ways do God's promises demonstrate his love for us?**
- ★ **How does seeing that God kept his promises to Abraham help us trust God more?**

Say: **God's promises are like precious jewels and treasures because they help us know God and have even greater faith in him. Just as God made promises to Abraham, God makes and keeps promises to us. Let's play a game of Promise Bingo as we learn more about God's promises.** Have kids keep their beads in the cups.

Help kids mark Genesis 12:1-7 in their Bibles, using the blue bookmark ribbons from last week. If anyone has lost or didn't make a bookmark, let that child make one now using an 8-inch length of blue ribbon and the Bible icon from page 123.



## THE MESSAGE IN MOTION

Before class, make photocopies of the Promise Bingo game board on page 125. You'll need one game board for each child. You'll also need crayons. (If you want, use the broken crayons from earlier.)

Distribute the Promise Bingo game boards and invite kids to color the Free space. Explain that you'll read a sentence clue and question. When kids know the answer, they can color the appropriate square on the game board. When

all the spaces are filled in, have kids shout “Bingo!” Read the following clues and questions:

1. God promised this man he would keep the animals and his family safe on a large boat. Who did God save with his promise? (Noah)
2. After this man crossed the Red Sea, God promised him that he would send bread from heaven to eat. Who did God promise to feed? (Moses)
3. This man was the perfect answer to God’s promise for a Savior to love us and forgive our sins. Who did God send as the answer to his most special promise? (Jesus)
4. God promised this man a new land, many descendants, and countless blessings. Who did God make these promises to? (Abraham)
5. God promised this woman she would have a heavenly baby who would grow up to become King and Savior of the world. Who did God promise this special baby? (Mary)
6. God promised never to flood the world again and put this in the sky as a symbol of his promise. What did God place in the sky? (a rainbow)
7. God promises to do this special thing for us every day of our lives. What does God promise to do? (love us)
8. God wrote down his promises in this special place. What is it? (the Bible)

When everyone has shouted “Bingo!” say: **We’re all winners! That’s because we can trust God to keep his promises! Here’s a blue bead to add to your collection to remind you how we’re all winners when we trust in God!** Hand out the blue beads, then ask:

- ★ **What can we learn from how God kept promises to these people?**
- ★ **What does God promise us?** (Answers may include to love us, help us, teach us, never leave us alone, and forgive us through Jesus.)
- ★ **How can we rely more on God and his promises?**

Say: **We can find faith in God through the promises he makes and the fact that he loves us enough to keep every one of those promises. We can also find faith through God’s Word. Let’s learn a new Mighty Memory Verse as we continue to discover more about our trust in God.**

## **SUPER SCRIPTURE**

Before class, purchase self-hardening clay from a craft store. This is clay that will air-dry and harden in several hours. If you can’t find self-hardening clay, you may wish to mix and use plaster of Paris. If you use plaster, simply pour

the plaster in a small plastic plate and have kids make handprints in the plaster, then poke the jewel beads on as rings or in designs in the plaster. When the plaster hardens, pop it out of the plate.



Gather kids, help them find Proverbs 3:5, and read the verse aloud two times, inviting kids to read along. Break the verse into two segments and repeat each two times. Then help kids mark the verse in their Bibles with the bookmarks they made several weeks ago. If kids have forgotten the bookmarks, have them make new ones out of 8-inch lengths of yellow ribbon and the Mighty Memory Verse icon from page 123.

Then say: **This verse tells us to do two things: trust in the Lord with all our hearts, and lean not on our own understanding. What do you think this means?** Invite kids to share their thoughts, then continue: **This verse tells us to trust God with all that we are even if it doesn't make sense and we don't understand. When we trust God and leave everything in his hands, we're on the right track even if we're not sure where we're headed.**

**Let's make nifty paperweights to remind us that everything is in God's hands when we trust him with our whole hearts! And here's a red heart bead to help us get started.**

Hand each child a piece of waxed paper and a glob of clay about the size of a small tennis ball. Show kids how to flatten the clay on waxed paper until it's about ½-inch thick, then push one of their hands down into the clay. Have kids use the other hand to mold the clay around and between their fingers to form a clay hand shape. Then tell kids to use their jewel beads to decorate the hands, making rings, bracelets, hearts, or other designs that they like. As kids work, have them visit about how God's promises can help us look forward to each day and get through tough times at school or at home. Remind kids that when we place our faith in God's promises, we show God we love and trust him.

Tell kids that, after the clay dries in several hours, they can peel away the waxed paper and use the hands as paperweights to remind them that God's promises are as solid as stone and filled with great treasures! Say: **We can find faith in God and his promises. Doesn't that feel wonderful? God makes and keeps his promises to us, so let's make our own promises to God and share a prayer thanking God for his faithfulness.**



## A POWERFUL PROMISE

Before class, you may wish to write the words to the song below on newsprint and attach it to a wall or door for kids to see as they sing.

Have kids sit in a circle and ask for a moment of silence. Then say:

**We've learned today that God shows us his love through his promises. We've also discovered that we can trust God to keep his promises. And we've started learning a new Mighty Memory Verse that tells us to trust God with all our hearts and to lean not on our own understanding.**

Hold up the Bible and say: **Because God loves us, he makes wonderful promises to us. But do you know what's even better than that? We can trust God to keep every one of his promises! Let's show God he can trust us to keep our promises to him, too. Listen to what the Bible says about being faithful to God in return.**

Read aloud Numbers 30:2. Then say: **We can make a promise to trust God with all our hearts this week and then keep that promise. As we pass the Bible around the circle, we can make our own special promise. We can say, "Lord, I will trust you with all my heart."** Pass the Bible until everyone has had a chance to make the promise. Then offer a prayer thanking God for his promises and asking for his help in trusting him to keep his Word in our lives.

Close by singing "P-R-O-M-I-S-E" to the tune of "Jesus Loves Me."

### P-R-O-M-I-S-E

**God will keep his Word to me.  
I can trust with heart and soul  
That God will keep his promise whole.  
Trust God with your heart.  
Trust God with your heart.  
Trust God with your heart—  
God keeps his promises.**



End with this responsive good-bye:

Leader: **May God's loving promises be with you.**

Children: **And also with you!**

Distribute the Power Page! take-home papers as kids are leaving. Thank kids for coming and encourage them to keep their promises to God this week.

# POWER PAGE!

## TRUST ME!

God wants us to trust with our hearts even if we don't understand. Read the surprising directions God gave these Bible people and how they trusted God with their hearts. **You'll be amazed!**

- Genesis 6:13-22
- Exodus 17:1-7
- Joshua 6:1-20
- Matthew 17:24-27

## Promise Power!

Read the Bible verses, then write the answer or draw a symbol of each promise.

Noah's Promise  
Genesis 9:11-13

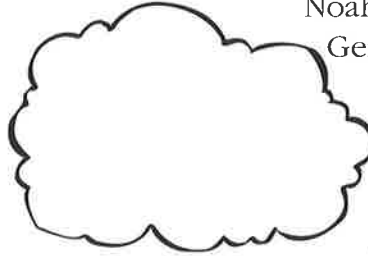

Abraham's Promise  
Genesis 15:5

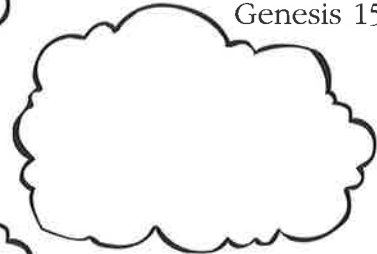

Our Promise  
Micah 5:2, 4, 5



Follow the arrows to plug in the missing letters from Proverbs 3:5.

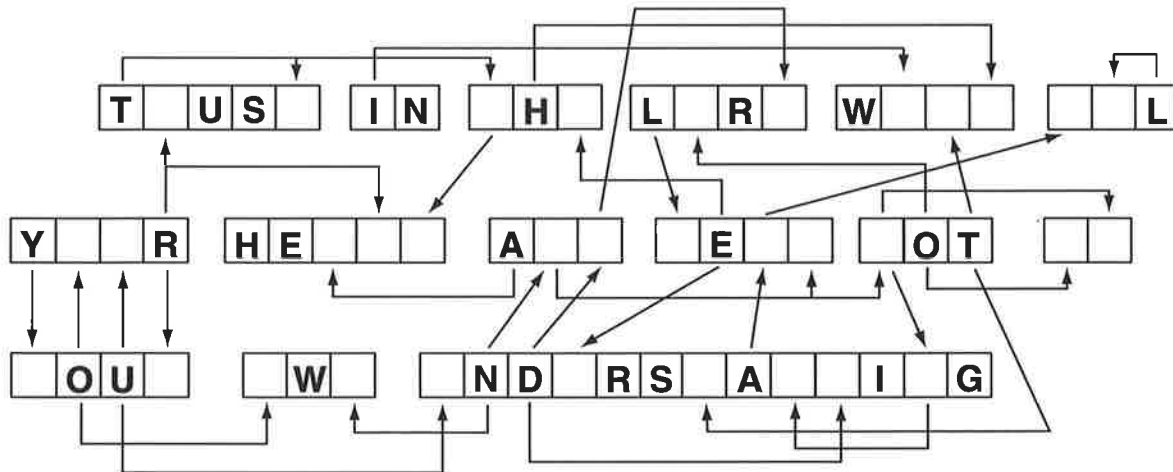

PROVERBS 30:5